

Quick Guide

5. Basic Phone Operation (Cont.)

To automatically forward incoming calls to another phone:

1. Press the **Forward** softkey (in the idle screen).
2. Select the condition upon which you want calls forwarded - **Always**, **Busy** or **No Reply**. If you choose **No Reply**, define after how many seconds the call is forwarded if not answered.
3. Enter the number to where you want to forward the calls, and then press the **Start** softkey.

To deactivate call forwarding, press the **Forward** softkey.

To make a three-way conference call:

1. Make a call to the first participant in the conference call.
2. Press the **Conf** softkey and then make a call to the second participant.
3. When the second party answers, press the **Conf** softkey.

To end the three-way conference call, hang up the phone or press the **End** softkey.

Notice Information

This Quick Guide describes the quick setup for Genesys 405HD IP Phone.

Information contained in this document is believed to be accurate and reliable at the time of printing. However, due to ongoing product improvements, Genesys cannot guarantee accuracy of printed material after the Date Published nor can it accept responsibility for errors or omissions. Updates to this document and other documents as well as software updates can be viewed on the Genesys documentation site at docs.genesys.com.

© Copyright 2018 Genesys Telecommunication Laboratories. All rights reserved.

This document is subject to change without notice.
 Date Published: December 2018
 Document : Genesys 405HD IP Phone Quick Guide



1. Before Installing

Congratulations on purchasing Genesys 405HD IP Phone! Before you begin using the phone, ensure that the following items are included in the shipped box:

- ✓ 405HD GbE IP Phone
- ✓ AC power adapter (optional)
- ✓ Cat 5e Ethernet cable
- ✓ Phone base stand
- ✓ Handset
- ✓ Handset cord

2. Physical Description



Genesys 405HD GbE IP Phone

Genesys 405HD GbE IP Phone

3. Cabling the Phone

 **Warning:** Prior to connecting power, refer to the Compliancy and Regulatory Information at <https://box.audiocodes.com/?u=sl8aSBN3QQFNAYqk&p=xFw4v13tiGu2Ga0J>.

To cable the phone:

1. Connect the short, straight end of the phone cord to the handset and the longer straight end of the cord to the handset jack on the phone.
2. Connect the RJ-9 headset jack to a headset port, or to the USB port (optional).
3. Connect the RJ-45 LAN port to your LAN network (LAN port or LAN switch/router) with a CAT 5 / 5e Ethernet cable.
4. Connect the RJ-45 PC port to a computer with a CAT 5 / 5e straight-through Ethernet cable.
5. Connect the connector tip of the AC power adapter to the phone's **DC 12V** power socket and connect the two-prong AC adapter directly to the electrical wall outlet. When the phone powers up, all the LEDs momentarily light up.

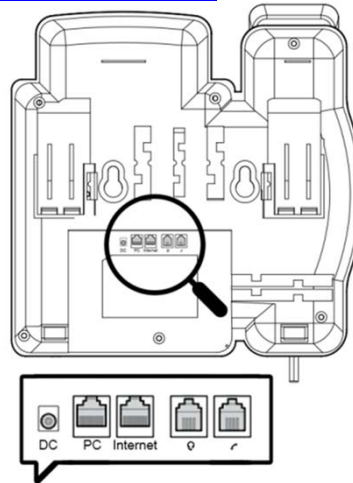







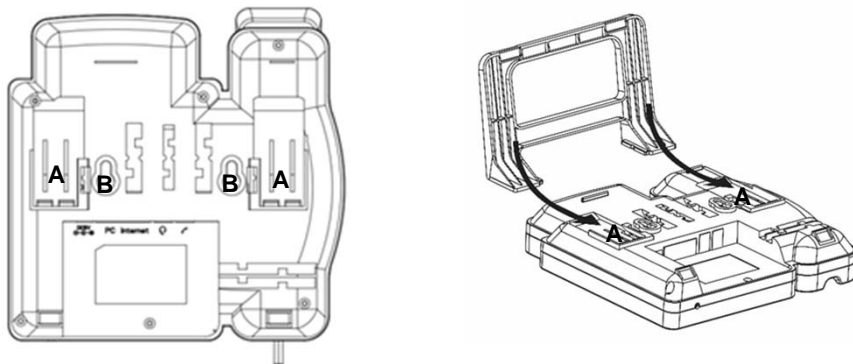

4. Mounting

 **Desktop mounting:** Slide the short edges of the L-shaped stand (the prongs) into the phone's two rear slots (see **A** below). Slide the prongs in until they lock.

 **Wall mounting:** Hook the phone's two rear notches (see **B** below) onto wall mounting screws. Pull out the handset's cradle clip, which is by default in desktop mounting position, invert it, and then push it back in. This is the wall mounting position.



5. Basic Phone Operations

-  **To make a call:** Pick up the handset, enter a phone number and then press the **Dial** softkey. To call a phone contact, press the directory icon softkey, access the Corporate or Personal directory, select the contact and then press the **Dial** softkey.
-  **To answer a call:** Pick up the handset, or press the **Accept** softkey.
-  **To end a call:** Return the handset to the phone cradle, or press the **End** softkey.
-  **To mute a call:** Press the mute  key. To resume the conversation, press the mute key again.
-  **To redial a number:** Press the REDIAL key, select a dialed number, and then press the **Dial** softkey.
-  **To put a call on hold and make another call:** Press the **Hold** softkey and then the **New Call** softkey, enter a phone number and press the **Dial** softkey. To return to the held call, press the down key and then press the **Resume** softkey.
-  **To transfer a call:**
 1. During a call, press the TRANSFER key, enter the phone number to where you want to transfer the call, and then press the **Dial** softkey.
 2. Either wait until the call is established to speak with the second party and then press the **Trans** softkey, or press the **Trans** softkey when the called party rings to transfer the call without speaking with the party.